

# WELDBABY 180



Instrument panel



4000 rpm Honda engine

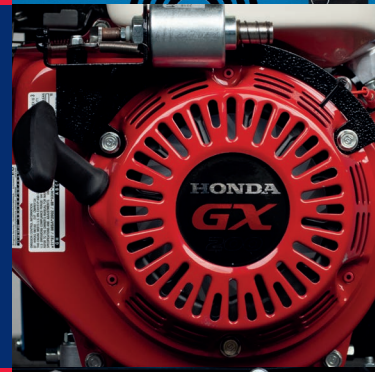

3.1 lt fuel tank

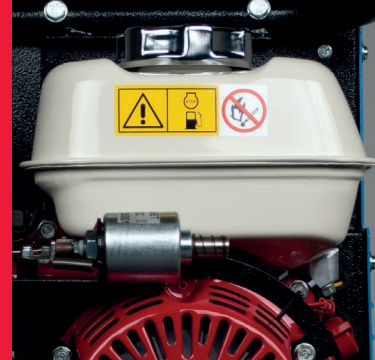

Unit of measure: mm

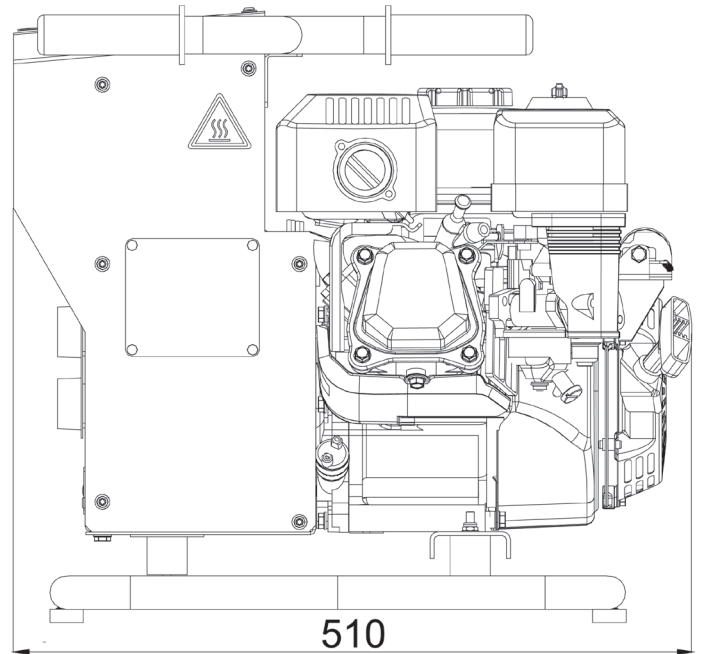
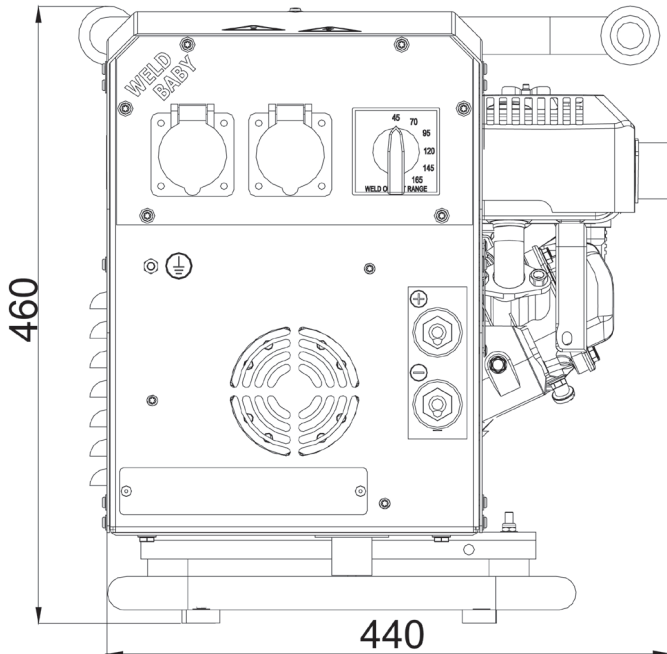

We reserve the right to change data, images and drawings without notice.  
For more information, you may contact your local dealer or Mase Generators S.p.A.

Mase Generators spa  
Via Tortona, 345 - 47522 - Cesena (FC) - Tel. +39 0547 354311  
www.masegenerators.com - commercial@masegenerators.com

**mase**  
**GENERATORS**  
Believing in change.



Output power 1 kW single-phase

## Description

- Portable engine driven welder
- Delivers 150 A of DC weld output
- Single-phase auxiliary power available
- 4000 rpm petrol engine

## Standard Features

### Welding processes: SMAW (stick)

- Low oil level shutdown device
- 1 x 16 A, 110 V single-phase EEC socket
- 1 x 16 A, 230 V single-phase EEC socket
- Switch breaker
- Automatic idle device when no load is connected

## Noise level

- Lwa 98 (73 dB a 7 mt)

## DC welding

- Duty Cycle @ 60%: 150 A - 24 V
- Output range: 40 A - 150 A
- Open Circuit Voltage: 70 V
- Max welding rod: 3,25 mm

## DC generator - 50Hz

- Type: synchronous, permanent magnets (PMG)
- Single-phase power: 1 kW - 230 V DC
- Single-phase power: 0,5 kW - 110 V DC

## Petrol Engine 4000 rpm

- Type: Honda GX 200 - STAGE V - 1 cyl. - 5,1 HP (3,8 kWm) - 196 cm<sup>3</sup>
- Cooling system: air
- Starting system: recoil
- Fuel tank capacity: 3,1 lt
- Fuel consumption @ 75%: 1,8 lt/h

## Other features

- Insulation Class: H
- Ambient temperature: 40 °C (\*)
- Altitude: 1000 mt (\*)
- Mechanical Protection: IP 23
- Dimensions (L x W x H): 510 x 440 x 460 mm
- Dry weight: 35 kg

(\*) - For altitude and temperature values other than those listed above, please consult the manufacturer to verify the available power.